

Transfer Case Application Guide

To help you determine which unit you're working on we have included the following application guide to popular Transfer Case models.

Borg Warner Tag

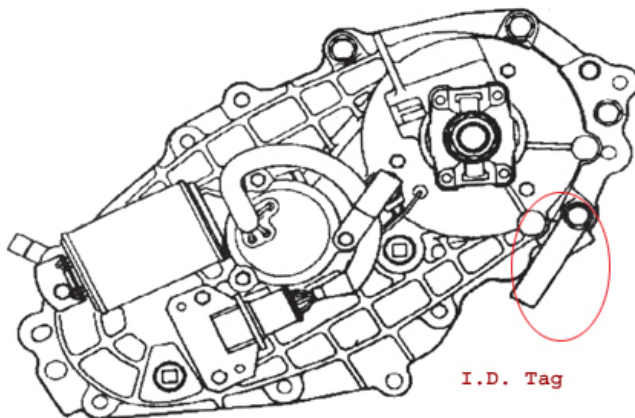

Build Code	Assembly Code Number
F552	4484-00
800293	1848-TF

Serial Number Assembly Number

New Process/New Venture Tag

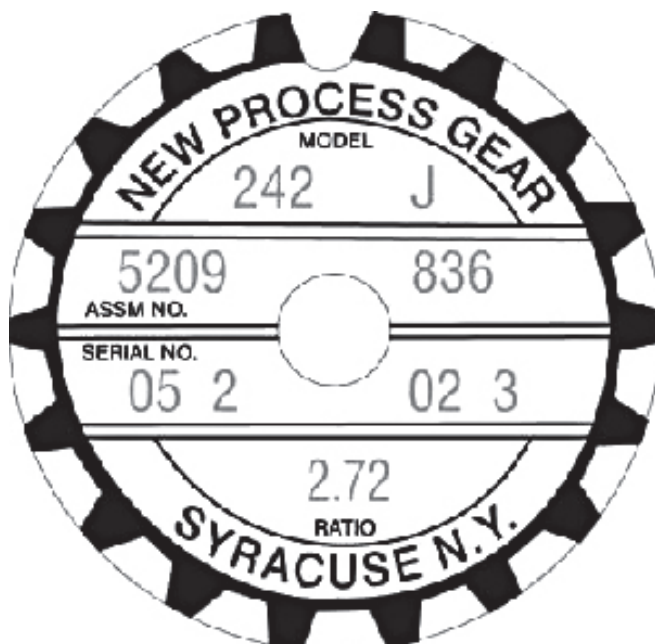

Top Semi-Circle = Model
Above Screw = OE Assembly number
Below Screw = OE Serial number
Bottom Semi-Circle = Ratio



TECH REFERENCE

Ford

Transfer Case	Application	Year Range	Points of Interest
NP203F	F150, F250, Bronco	1973-79	Full time unit, heavy-duty, cast iron, chain driven, direct and remote mounting
NP205F	F150, F250, Bronco	1973-79	Part time unit, heavy-duty, cast iron, chain driven, direct and remote mounting
NP208F	F150, F250, Bronco	1980-86	Part time, aluminum case
NP271F	F250-550	1999-up	Heavy-duty manual shift, aluminum case
NP273F	F250-550	1999-up	Heavy-duty electric shift, aluminum case
BW1345F	F250	1980-92	Magnesium case, medium-duty, manually shifted. Case 1345
BW1350F	Bronco II, Ranger, Explorer	1983-89	Light-duty, magnesium case. Manual & electric shift
BW1354F	Bronco II, Ranger, Explorer	1987-97	Light-duty, magnesium case. electric shift
BW1356F	Full Size Bronco, F150, F250	1987-97	Medium-duty, magnesium case, Manual & electric shift. Cast 1356
BW4404F	Explorer & Mountaineer	1996-up	Medium-duty, magnesium case, all wheel drive equipped with viscous coupling
BW4405F	Explorer, Ranger & Mountaineer	1995-99	Electric shift, clutch pack driven torque transfer.
BW4406F	F150, F250, Expedition, Navigator	1997-03	Electric shift, manual shift, and torque-on-demand models.
BW4416	F150, F250, Expedition, Navigator	2004-up	Electric shift, and torque-on-demand models.
BW4407F	F250, F350	1996-99	Medium-duty, magnesium case, manual shift. Built with and without PTO option
Dana28	Aerostar AWD models	1990-96	Magnetic clutch actuated torque transfer

GMC

Transfer Case	Application	Year Range	Points of Interest
NP203C	Blazer, K series	1973-79	Heavy-duty chain driven, cast iron case found behind manual trans, TH350, TH400
NP205C	Blazer, K10-30	1966-84	K30 and 3500 series trucks 1984 and up. Heavy-duty cast iron, gear driven unit. Found behind SM465, TH350, and TH400
NP207C	S10 & Jimmy	1983-87	Light-duty, aluminum case with manual shift
NP208C	Full size Blazer, Jimmy, & Pick-ups	1981-88	Part time, aluminum case built in synchronized and non-synchronized models
NP231C	S10, Jimmy & Pick-ups	1988-97	Light-duty, aluminum case. Built with and without torque arm, cable and electric speedo, manual shift.
NP233C	S10, Jimmy & Pick-ups	1992-up	Light-duty, aluminum case, electric shift, built with and without torque arm
NP241C	Astrovan, Safari, GMC & Blazer	1987-98	Medium-duty, aluminum case, electric shift. Part time unit
NP243C	Blazer, Suburban, Tahoe, Yukon, & Pick-ups	1996-up	Medium-duty, aluminum case, electric shift. 4L60E & 4L80E Trans.
NV246C	Tahoe, Yukon, Suburban	1998-up	Medium-duty, magnesium case, electric shift
BW1370C-BW4470C	K3500	1992-00	Part time unit with 3-piece magnesium case with oil pump spacer place
BW4401C	K3500	1992-00	Part time unit, magnesium case without oil pump spacer
BW4472C	Astrovan, Safari, Bravado, Typhoon, Cyclone	1991-98	Full time unit, magnesium case with viscous coupling
NP136C	Astrovan, Safari, Blazer	1998-up	All wheel drive unit with electric clutch pack apply



TECH REFERENCE

Dodge

Transfer Case	Application	Year Range	Points of Interest
NP203D	Ram Charger, W100-300 models	1973-79	Heavy-duty, cast iron case, chain driven, full time unit. Direct and remote mount
NP205D	W100-350 Ram Trucks	1982-93	Heavy-duty, cast iron case, gear driven, part time unit
NP208D	Ram Charger & Pick-ups	1980-88	Medium-duty, aluminum case, part time unit. Built in synchronized and non-synchronized models
NP231D	Dakota, W150 & Durango models	1987-01	Light-duty, aluminum case, part time unit. Manual shift unit with a number of variations of vacuum and electric shift. Can have 2 different shift patterns
NP241DLD	Ram Charger, W150-250 models	1987-up	Light-duty, aluminum case, part time unit. Manual shift unit. Can have 2 different shift patterns
NP241DHD	W350 Pick-ups		Heavy-duty, part time unit with aluminum case. 2 types of shift patterns. All models equipped with PTO
NP242D	Durango, Dakota	1997-00	Part time-full time unit with internal differential for full time use.

Jeep

Transfer Case	Application	Year Range	Points of Interest
Quadratrac Dana 300	Jeep Cherokee CJ 7 models, CJ5, CJ7, CJ8	1973-79 1980-86	Full time unit with cone clutch differential. Some models have a low reduction unit. Cast iron case, part time unit with manual shift
NP128J	AMC Eagle	1986-88	Full time unit without viscous coupling
NP129J	AMC Eagle	1979-85	Full time unit with viscous coupling
NP207J	Wrangler Cherokee models	1983-88	Part time, aluminum case, manual shift
NP208J	Wrangler, J10, Cherokee models	1980-83	Part time, aluminum case, manual shift
NP219J	Wagoneer, Cherokee, & Pick-ups	1980-83	All wheel drive with viscous coupling
NP228J	Cherokee, Wagoneer, Grand Cherokee	1986 only	Part time unit, aluminum case. Vacuum and mechanical shift without viscous coupling
NP229J	Cherokee, Wagoneer, Grand Cherokee	1982-92	Part time unit, aluminum case. Vacuum and mechanical shift with viscous coupling
NP231J	YJ, TJ, ZJ, WJ, XJ	1987-up	Part time unit, aluminum case with manual shift. Wide variety of vacuum and electric switches. Produced with live shaft and extension housing
NP242J	Cherokee/Grand Cherokee	1987-up	Part time, full time unit, aluminum case with internal differential. Produced with live shaft and extension housing. Manual shift.
NV274J	Grand Cherokee, WJ models	1999-up	Full time unit with progressive coupling. Uses two internal pumps and clutch pack for torque transfer. Manual shift for low lock only
NP249J	Cherokee/Grand Cherokee	1993-up	Full time unit with viscous coupling. Manual shift. Produced with and without low lock

This page has been compiled with the utmost of care from reliable information and sources. Although every precaution has been taken to assure the accuracy of the information, King-O-Matic cannot and does not assume any responsibility for errors, omissions or misapplications.

Please review the terms and conditions associated with this piece. A link to the terms and conditions can be found at the bottom of this page